



BLACKCAM™

blackcamsystem.com

**Blackcam™ System B40 –
Technical Specifications**

(Version 20.03.2017)

Camera

Camera:	Sony HDC-P1, 3-CCD, 2/3-inch type, 16:9
Lens:	2/3" B4 bayonet mount, ENG
Sensitivity:	F11 at 2000 lx (3.200K, 89,9 reflectance)
Horizontal resolution:	1000 TV lines (at Centre)
Output:	1080i/50, 1080i/59.94, 720p/50, 720p/59,94 14bit SDI/HD-SDI via BNC
Power supply:	V-Mount battery or cable

Dolly

Please check drawings attached for all measures.

Speed:	Standard 4 m/s (<i>13ft/s</i>), highspeed version on request
Power supply:	Cable or battery operation
Batteries:	LiPo batteries for dolly movement, runtime approx. 2hrs

Track

Dimensions:	30cm width x 12cm height (<i>11.81in width x 4.72in height</i>), black anodized
Weight:	4kg/m (<i>8.82lbs/3.28ft</i>)
Pieces:	Standard length: 4m, 2m, 1m, 50cm (<i>13.12ft, 6.56ft, 3.28ft, 1.64ft</i>) Custom length possible
Curves:	Minimum inner radius: 1m (<i>3.28ft</i>) Several radiuses on stock, customized radius possible

Production cabling

Camera signal:	HD-SDI via BNC, return PGM-Mix as SD/HD-SDI
Tally:	XLR3 (dry contact between pin 2+3)
RCP:	2 x XLR3 or 1 x XLR5 or 1 CAT5/RJ45
Intercom:	Listen + Talkback via 2 x XLR3
Power:	1 x 16Amp Schuko at operator desk

Miscellaneous

Operator desk:	Non-restricted view to tracks is recommended
Tracks:	Wireless setups always need an off-park-position (i.a. battery change) Access to tracks must be possible If applicable, protection against audience contact is necessary
Radio backup:	If applicable, allow for cable run tracks <> operator desk



Technical Drawing Blackcam™ B40 System

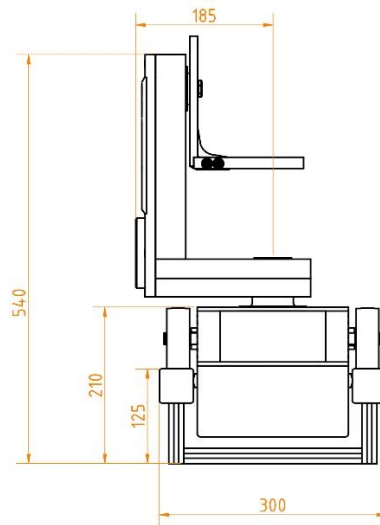

For straight tracks:

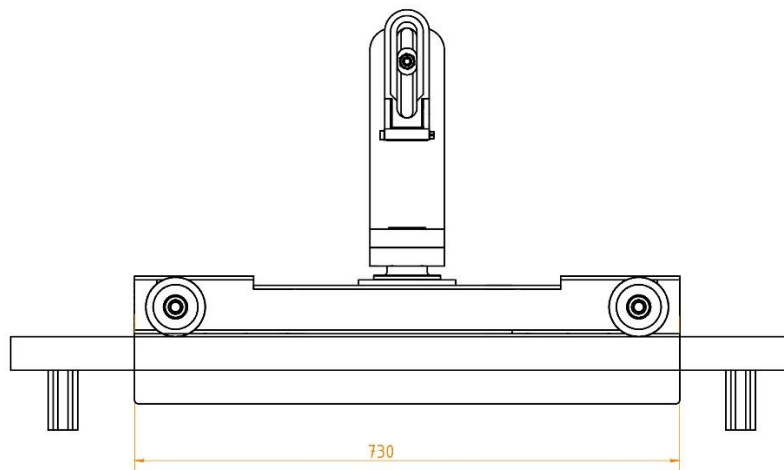

For curved tracks:

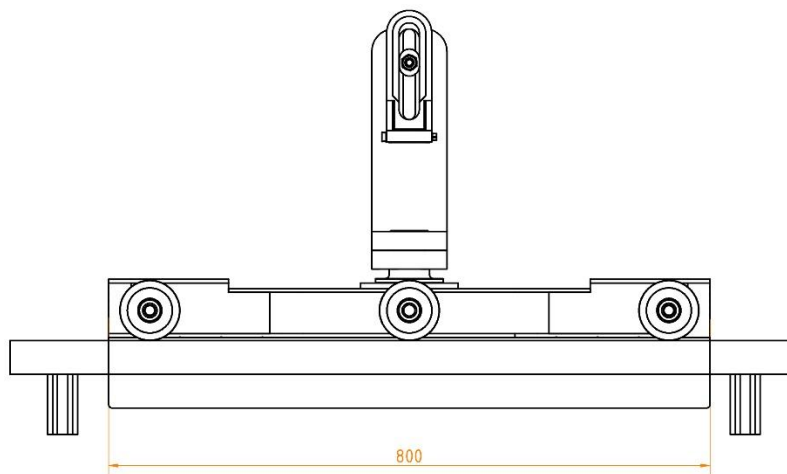

**all dimension in mm*